

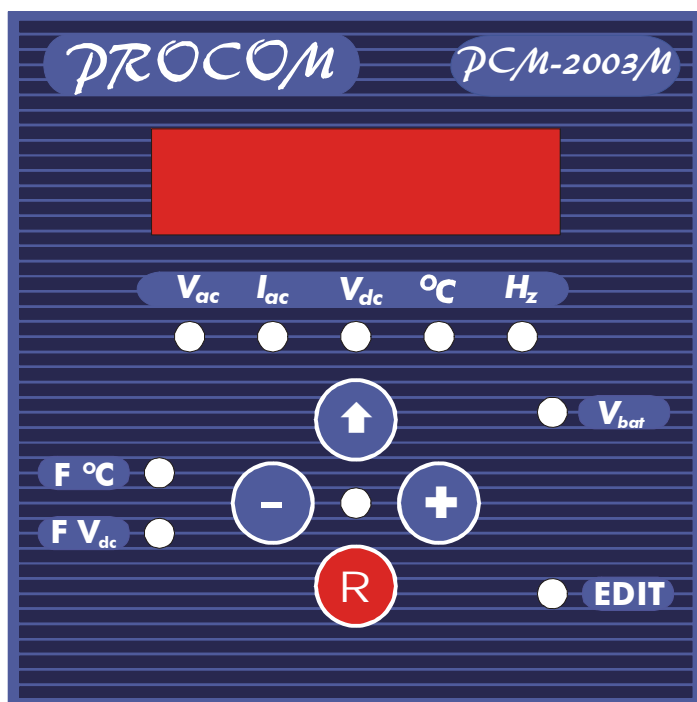

OPERATING INSTRUCTION: PCM-2003M



MRM **PROCOM** Pvt Ltd

Works:

E 41/5 , Okhla Industrial Area, Phase II, New Delhi -110020

Ph: 011-30883537-39, 9310883837, 9810344265 Fax: 011-30883536

Email:mrmprocom@gmail.com, website: www.mrmprocom.com

Corporate office:

238, Sukhdev Vihar, New Delhi -110025

Ph: 26913223

Index

- 1.1 Introduction
- 1.2 Salient Feature of the PCM-2003M
 - 1.2.1 Measurement
 - 1.2.2 Protection
- 1.3 Function
- 1.4 Display
- 1.5 Programming Mode
 - 1.5.1 Setting Table
- 1.6 Switch Description
- 1.7 Specification
- 1.8 Connection Diagram

PCM-2003M

Multifunction Meter with protection

1.1 Introduction

- The microcontroller based PCM2003M; Multifunction meter combines the measurement functions along with DC voltage and temperature supervision.
- Housed in 96 x 96 flush mounted enclosure.

1.2 Salient features of the PCM2003M

1.2.1 Measurement:

- AC Voltage with true RMS measurement
- AC Current with true RMS measurement
- DC Voltage 10 – 72 VDC (for supervision)
- DC Voltage 9 to 36 VDC (Auxiliary supply voltage for unit operation)
- Temperature 0 °C TO 60 °C

1.2.2 Protection.

- DC under voltage (supervisory voltage)
- Over temperature

1.3 Function:

PCM2003M monitors the above mentioned parameters and provide protection for over-temperature and DC under voltage for 48 /24VDC nominal supply input. The DC under voltage protection has two inbuilt programmable timer one for pick-up / trip time setting the other for reset / release time. In case the DC under voltage condition persist for more than the set time of trip delay, VDC contact operates and the cause of tripping is indicated on the front panel (F V_{dc} LED start glowing). The DC voltage supervision has programmable hysteresis (pickup to dropout ratio) setting

The over temperature protection has two inbuilt programmable timer, one for pick-up / trip time the other for reset / release time. In case the over-temperature condition persist for more than the set time of trip delay, temp contact operates and the cause of tripping is indicated on the front panel (F°C LED start glowing). The over temperature supervision has programmable hysteresis (pickup to dropout ratio) setting

The AC current is displayed in primary values. The CT ratio is user programmable.

The meter also has a test feature. On pressing the Test key both the contacts operates for the set time delay (User programmable) and the reverse counting of the remaining time is displayed. After expiry of the reverse counter the meter returns to the normal protection and supervision mode. Test mode can be prematurely terminated by again pressing the Test Key.

1.4 Display:

It has 4 Seven Segment bright LED display, to display the measured parameters and settings. Beside the numeric display there are 10 LEDs for annunciations as shown below.



1.5 Programming mode:

Programming mode can be entered any time by simultaneously pressing **+** & **-** keys. In program mode the EDIT LED lights up indicating programming mode. The 4th digit (left most) shall have a digit indicating the parameter under programming. The following table details the various programmable parameters:

1.5.1 Setting table

Sl.No	Display on 4 th Digit	Parameter	Explanation of parameter	Factory setting	Setting Range
1	1	DC Under Voltage	Voltage healthy limit : Below this the DC voltage is treated as unhealthy	45 VDC	18 - 60VDC
2	2	DC Under Voltage hysteresis	In case the unit trips on under voltage, the unit shall reset when the voltage goes above the user defined over voltage limit plus this parameter.	3.0 V	1.0 – 15.0 V
3	3	Trip Delay for DC Under Voltage	Time for which the DC voltage has to be lower than DC under voltage setting for generating trip command.	10 Sec	0-999Sec
4	4	Reset Delay for DC under voltage	The trip relay resets if the DC voltage remains above the user defined over voltage limit plus hysteresis for this time delay	10 Sec	0-999Sec
5	5	Over Temperature	Temperature healthy limit: Above this, the temperature is treated as unhealthy	27°C	10 - 50 °C
6	6	Over Temperature hysteresis	In case the unit trips on over temperature, the unit shall reset when the temperature goes below the user defined over temperature limit minus this parameter and remains there for reset time delay	3.0 °C	1.0 – 15.0 °C

7	7	Trip Delay for over temperature	Time for which the temperature has to be above than over temperature setting for generating trip command.	10 Sec	0-999Sec
8	8	Reset Delay for over temperature	The trip relay resets if the temperature remains above the user defined over temperature limit plus hysteresis for this time delay	10 Sec	0-999Sec
9	9	CT Ratio	The current is displayed in primary values. The injected current is multiplied by CT ration .The multiplied value is displayed as measured current.	1	1-99
10	A	Test Time	On pressing the test button both the trip contacts operates and remain operated till the expiry of test time. After that the unit returns to its normal functioning.	300 Sec	10-999Sec

1.6 Switches Description:

S.No.	Switch Symbol	Switch Function	Description
1	↑	Next	Normal operation mode: In this mode, next is used to select the measured parameters. The corresponding LED shall light up to indicate the parameter that is displayed. Programming Mode: Next key is used to select the next parameter to be programmed.
2	+	Increment	This key is only active during programming mode and is used to increment the value of the parameter under programming.
3	-	Decrement	This key is only active during programming mode and is used to decrement the value of the parameter under programming.
4	⊙	Test	On pressing the Test key the meter goes to test mode.
5	+ & -	Programming Mode Entry	If both the keys are pressed simultaneously the unit will enter in programming mode.

1.7

Specifications

AC voltage \	
Measurement	25V-300V
Withstand	400 VAC continuously (Phase to neutral)
Accuracy Class	I
AC Current	
Ib	5 A
Imax	10A
Withstand	20A
Accuracy Class	I
Temperature	0-60 C
Measurement Accuracy	1 °C +1%
Auxiliary Supply Voltage	10V-36V
DC Voltage withstand (Aux)	36 VDC
DC Voltage with stand (Sup)	72 VDC
Measurement Accuracy	1%
Surge 1.2/50Usec	2.5KV
Out Put Contact	1 NO & 1 Change over
Contact Rating	230V / 6A
Cut out Dimensions	90mm X 90mm
Depth	120mm

1.8

Connection Diagram

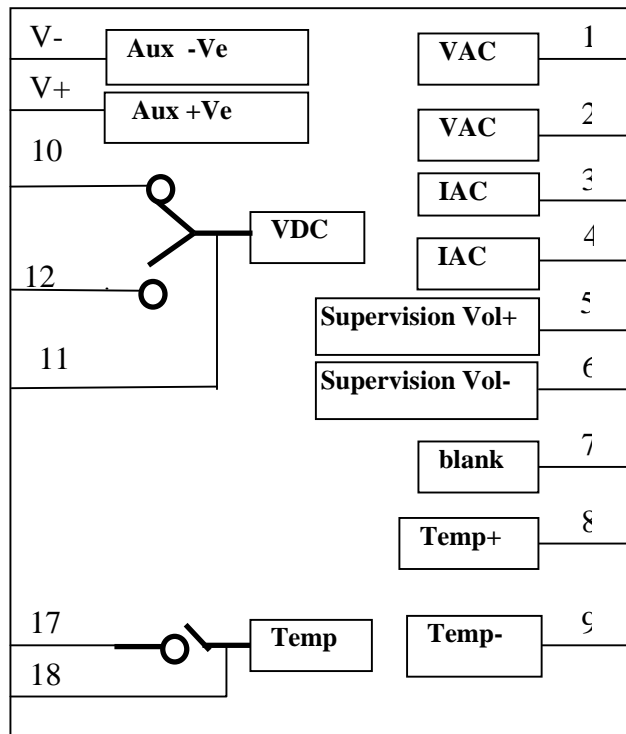

It is our endeavour to constantly upgrade our products, hence specifications are subject to change without any notice.