

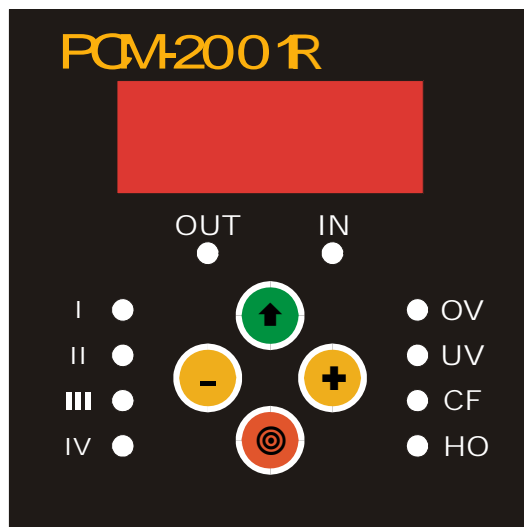

**OPERATING INSTRUCTION: PCM-2001R**  
**4 Stage Automatic Voltage regulators**





## ***Index***

- 1.1 Introduction
- 1.2 Salient Feature of the PCM-2001R
  - 1.2.1 Measurement & Display
  - 1.2.2 LED Indications
  - 1.2.3 Timer
- 1.3 Function
- 1.4 Display
- 1.5 Programming Mode
  - 1.5.1 Setting Table
- 1.6 Annunciation LED Functions
- 1.7 Switch Description
- 1.8 Faults
- 1.9 Output Contacts
- 1.10 Specification
- 1.11 Connection Diagram

## **1.1 Introduction**

- The Microprocessor / microcontroller based PCM2001R automatic voltage regulator is designed for ease of operation with inbuilt securities.
- Housed in 96 x 96 flush mounted enclosure.

## **1.2 Salient features of the PCM2001R**

- Programmable output voltage range.
- 4 Stage tap selector
- Programmable under/over voltage setting for input with programmable time delay.
- Innovative scheme to implement interlocking of contactors without any check back from the contactors.
- Alarm on contactor malfunctioning
- True RMS measurement with better than 1% accuracy of reading.
- Wide range of voltage input and measurement

### **1.2.1 Measurement & Display.**

PCM2001R, equipped with four seven segment display, displays:

- Output Voltage
- Input Voltage
- Set values

### **1.2.2 LED Indication**

- Status Indication for the current Tap in use (4)
- Output voltage
- Input voltage
- Trip on under voltage(Input Voltage)
- Trip on over voltage (Input Voltage)
- Fault: Contactor Latched
- Hooter ON

### **1.2.3 Timers**

Following timers are incorporated in the PCM2001R

- Input under/over voltage supervision timer.
- Hooter: 30Sec

## **1.3 Function:**

PCM2001R monitors the output supply for the programmed range. In case of the output voltage either being higher or lower than the programmed range it closes the tap in use and switches to a tap higher or lower than the current tap depending upon the output voltage. PCM-2001R implements innovative scheme for

interlocking the contactors. Before changing the tap the unit closes all the taps and monitors the output voltage. A fall in the output voltage indicates the successful closure of the tap and it's safe to engage another tap, in case of failure of contactor or its contact welding the output voltage shall not fall and PCM2001R will not try engaging the next tap, thereby avoiding a short circuit. In case of welding of a contact the unit shall give alarm for 30 seconds and cease to function till the problem is corrected.

PCM2001R also monitors the input voltage and in case of input voltage higher or lesser than the programmed range for the programmed time it opens its entire taps and waits for the input to become healthy. User programmable hysteresis is inbuilt to void chattering of the contacts.

Whenever the unit starts up either with on power on or after the input voltage has become healthy, it starts from First tap to avoid a sudden high output voltage.

There is 3 second delay between two successive tap change, this helps in contactors settling down, measurement being accurate and avoid contactors chattering.

#### **1.4 Display:**

It has 4 Seven Segment bright LED display, to display voltages. Beside the numeric display there are 9 LEDs for annunciations as shown below.

The right most 3 digits are in normal use and they display the following:

- a) Output Voltage
- b) Input Voltage

The 4<sup>th</sup> digit (left most) is used during the parameter-programming mode. The digit displayed on this indicates the parameter being programmed.

#### **1.5 Programming mode:**

Programming mode can be entered any time by simultaneously pressing **+** & **-** keys. While in program mode, the 4<sup>th</sup> digit (left most) shall have a digit indicating the parameter under programming. The following table details the various programmable parameters:

### 1.5.1 Setting table

Sl.No	Display on 4 <sup>th</sup> Digit	Parameter	Explanation of parameter	Factory programmed Value	Setting Range
1	1	Output voltage Upper Limit	This defines the maximum permissible output voltage	240V	80-270V
2	2	Output voltage Lower Limit	This defines the minimum permissible output voltage	210V	80-270V
3	3	Input voltage Upper Limit	This is the maximum permissible input voltage and a voltage beyond this will disable the regulator function.	460V	250-500V
4	4	Input voltage Upper Limit	This is the minimum permissible input voltage and a voltage beyond this will disable the regulator function.	300V	250-500V
5	5	Input voltage invalid time delay	The input voltage has to be, continuously outside the programmed range for the duration programmed in here for the unit to disable the regulatory function.	5 Sec	0-999Sec
6	6	Hystersis for over voltage	In case the unit trips on over voltage, the unit shall restart when the voltage falls below the user defined over voltage limit minus this parameter	10	5-35

7	7	Hystersis for under voltage	In case the unit trips on under voltage, the unit shall restart when the voltage goes above the user defined under voltage limit plus this parameter	10	5-35
---	---	-----------------------------	--	----	------

### 1.6 Annunciations LED's Functions:

S, No.	LED Nomenclature	Description
1	I	Indicates that tap I is selected.
2	II	Indicates that tap II is selected.
3	III	Indicates that tap III is selected.
4	IV	Indicates that tap IV is selected.
5	UV	FLASHING: The input voltage is lesser than the programmed value
6	OV	FLASHING: The input voltage is higher than the programmed value
7	OUT	The seven segment is displaying output voltage
8	IN	The seven segment is displaying input voltage
9	CF	Wielded contact for the TAP whose LED is ON
10	HO	Hooter ON

### 1.7 Switches Description:

S.No.	Switch Symbol	Switch Function	Description
1	↑	Next	<b>Normal operation mode:</b> In this mode, next is used to toggle between input and output voltages on the display. The corresponding LED shall light up to indicate the parameter that is displayed. <b>Programming Mode:</b> Next key is used to select the next parameter to be programmed.
2	+	Increment	This key is only active during programming mode and is used to increment the value of the parameter under

			programming.
3	-	Decrement	This key is only active during programming mode and is used to decrement the value of the parameter under programming.
4	⊙	Reset	This reset the hooter in case the hooter is ON otherwise it restarts the unit after the fault is corrected
5	+ & -	Programming Mode Entry	If both the keys are pressed simultaneously the unit will enter in programming mode.

**1.8 Faults:** In case of welded contactor the unit shall issue an alarm. Pressing the reset key can silence the hooter. Second press of this key shall indicate that the user has cleared the fault and the unit shall restart. **Please note that till the fault is not cleared the unit shall not function.**

**1.9 Output Contacts:**

All contacts are Normally open (NO) type except the tap I contact which is Normally Closed (NC) type.

**1.10 Specifications**

AC voltage withstand	600 VAC
Measurement Accuracy	1%
Surge 1.2/50Usec	2.5KV
Battery Voltage	Suitable for 12V/24 VDC System
Max. Battery Voltage	35V
Out Put Contact	5 NO
Contact Rating	230V @6A or 440V@2A
Cut out Dimensions	96mm X 96mm
Depth	120mm

1.11 Connection Diagram`

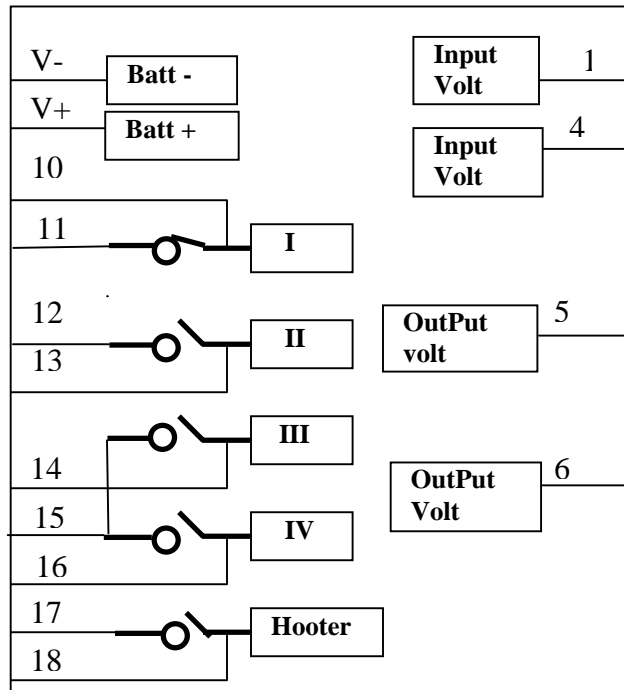

*It is our endeavour to constantly upgrade our products, hence specifications are subject to change without any notice.*