

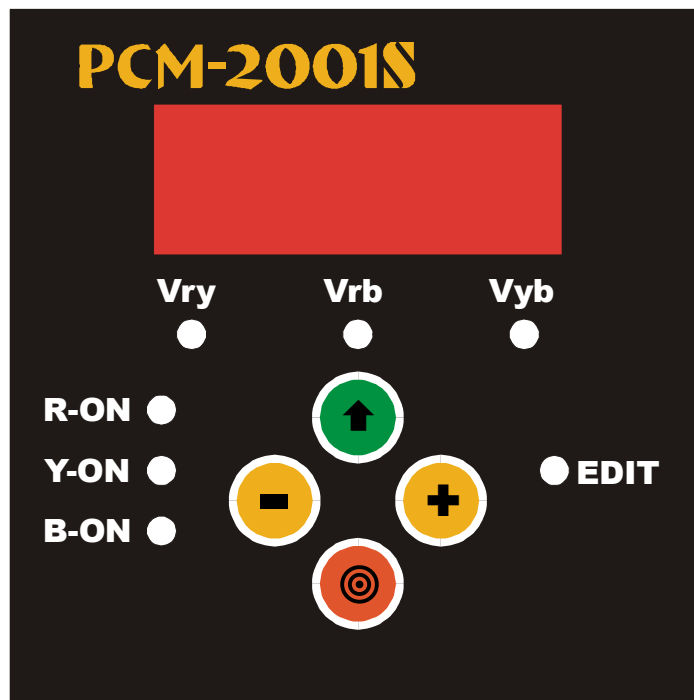

OPERATING INSTRUCTION: PCM-2001S
Automatic Voltage Selector



MRM *PROCOM* Pvt Ltd

Corporate office:

238, Sukhdev Vihar, New Delhi -110025

Ph: 26913223 **Works:**

E 41/5, Okhla Industrial Area, Phase II, New Delhi -110020

Ph: 011-30883537-39, 9313213223, 9810388177 Fax: 011-30883536

Email: mrmprocom@rediffmail.com

Index

- 1.1 Introduction
- 1.2 Salient Feature of the PCM-2001S
 - 1.2.1 Measurement & Display
 - 1.2.2 LED Indications
 - 1.2.3 Timer
- 1.3 Function
- 1.4 Display
- 1.5 Programming Mode
 - 1.5.1 Setting Table
- 1.6 Annunciation LED Functions
- 1.7 Switch Description
- 1.8 Output Contacts
- 1.9 Specification
- 1.10 Connection Diagram

1.1 Introduction

- The Microprocessor / microcontroller based PCM2001S automatic voltage selector is designed for ease of operation.
- Housed in 96 x 96 flush mounted enclosure.

1.2 Salient features of the PCM2001R

- Automatically selects the healthy phases in 3 Phase 3 Wire system
- Programmable input voltage range.
- Programmable under/over voltage setting for input with programmable time delay.
- Programmable, separate, under and over Hysteresis settings
- True RMS measurement with better than 1% accuracy of reading.
- Wide range of voltage input and measurement

1.2.1 Measurement & Display.

PCM2001S, equipped with four seven segment display, displays:

- Input Voltage for RY, RB & BY phases
- Set values

1.2.2 LED Indication

- Status Indication for the current Phases in use
- Input voltages

1.2.3 Timers

Following timers are incorporated in the PCM2001S

- Input under/over voltage supervision timer.

1.3 Function:

PCM2001S monitors the input line voltage for their healthiness. In case of the current selected line voltage outside the set limit of under/over voltage for the programmed delay time, PCM-2001S will select the next healthy line. In case of all the line voltages outside the range PCM-2001S will switch off all the line voltages and shall begin the operation only when any of the line voltage is between the under voltage programmed limit plus under voltage hysteresis voltage and is lower than the programmed over voltage and over voltage hysteresis.

1.4 Display:

It has 4 Seven Segment bright LED display, to display voltages. Beside the numeric display there are 9 LEDs for annunciations as shown below.

The right most 3 digits are in normal use and they display the following:

- a) Input Line Voltage

The 4th digit (left most) is used during the parameter-programming mode. The digit displayed on this indicates the parameter being programmed.

1.5 Programming mode:

Programming mode can be entered any time by simultaneously pressing **+** & **■** keys. While in program mode, the 4th digit (left most) shall have a digit indicating the parameter under programming. The following table details the various programmable parameters:

1.5.1 Setting table

Sl.No	Display on 4 th Digit	Parameter	Explanation of parameter	Factory programmed Value	Setting Range
1	1	Input voltage Upper Limit	This defines the maximum permissible output voltage	480V	250-500V
2	2	Input voltage Lower Limit	This defines the minimum permissible output voltage	280V	250-500V
3	3	Input voltage invalid time delay	The input voltage has to be continuously be outside the programmed range for the duration programmed in here for the unit to disable the regulatory function.	5 Sec	0-999Sec
4	4	Hystersis for over voltage	In case the unit trips on over voltage, the unit shall restart when the voltage falls below the user defined over voltage limit minus this parameter	10	5-35
5	5	Hystersis for under voltage	In case the unit trips on under voltage, the unit shall restart	10	5-35

			when the voltage goes above the user defined under voltage limit plus this parameter		
--	--	--	--	--	--

1.6 Annunciations LED's Functions:

S, No.	LED Nomenclature	Description
1	R-ON	R Phase contactor is on
2	Y-ON	Y Phase contactor is on
3	B-ON	B Phase contactor is on
4	EDIT	The unit is in EDIT Mode
5	Vry	The display quantity is line voltage of R-Y
6	Vrb	The display quantity is line voltage of R-B
7	Vyb	The display quantity is line voltage of Y-B

1.7 Switches Description:

S.No.	Switch Symbol	Switch Function	Description
1	↑	Next	Normal operation mode: In this mode, next is used to toggle between input voltages(Vry,Vrb,Vyb) on the display. The corresponding LED shall light up to indicate the parameter that is displayed. Programming Mode: Next key is used to select the next parameter to be programmed.
2	+	Increment	This key is only active during programming mode and is used to increment the value of the parameter under programming.
3	-	Decrement	This key is only active during programming mode and is used to decrement the value of the parameter under programming.
4	⊙	Reset	At present no function is assigned to this key
5	+ & -	Programming Mode Entry	If both the keys are pressed simultaneously the unit will enter in programming mode.

1.8 Output Contacts:

All contacts are Normally open (NO) type except

1.9 Specifications

AC voltage withstand	600 VAC
Measurement Accuracy	1%
Surge 1.2/50Usec	2.5KV
Battery Voltage	Suitable for 12V/24 VDC System
Max. Battery Voltage	35V
Out Put Contact	5 NO
Contact Rating	230V @6A or 440V@2A
Cut out Dimensions	96mm X 96mm
Depth	120mm

1.10 Connection Diagram`

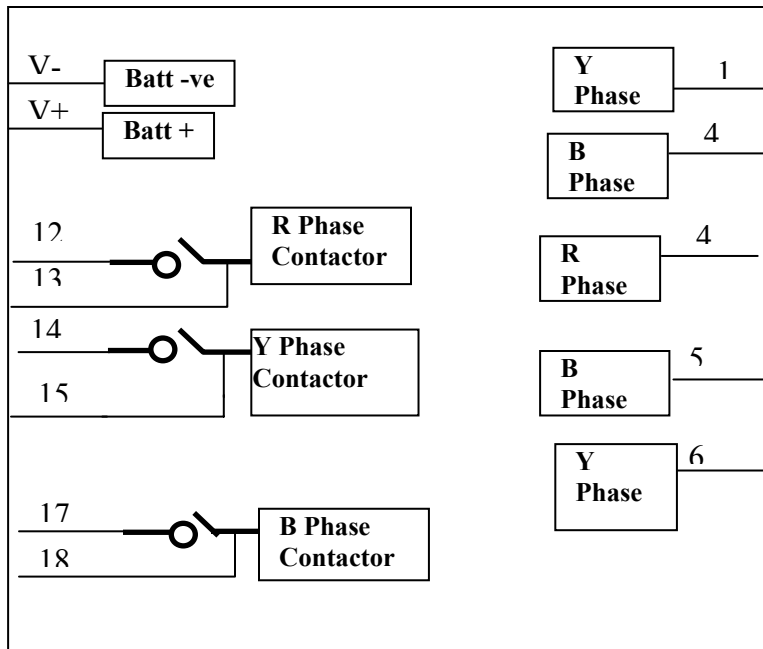

It is our endeavour to constantly upgrade our products, hence specifications are subject to changes without any notice.