



OPERATING INSTRUCTIONS COP-P (ANSI –32R)



MRM **PROCOM** Pvt Ltd

An ISO-9001-2008 certified organization

Works: Plot No. 20-21, Sector 59, Phase –II, Faridabad, Haryana -121004

Ph: 0129-4700400 (10 lines) Email: pankajgupta@mrmprocom.com,

Web: www.mrmprocom.com

INDEX

- 1. Introduction**
- 2. Protection, Supervision Salient features**
- 3. Contacts**
- 4. Front Panel Switch**
- 5. Setting Procedure**
- 6. Parameter Mode**
- 7. External Alarm Contact**
- 8. Set Blocking Function**
- 9. Reset – Auto / Manual**
- 10. Terminal Description**
- 11. Model Selection Chart**
- 12. Technical Specification**
- 13. Connection Diagram**

1.0 Introduction

- 16 Bit RISC, state of art, microcontroller based System.
- Fundamental measurement of all measured parameters with 1% accuracy of measured value (Not full scale)
Backlit LCD Display for easy reading and parameter settings. No need to consult the manual while programming the unit. All system parameters are user programmable
- All the inputs such as AC voltage and auxiliary voltage are completely isolated
- Fast Fourier Transformation to extract fundamental components of current and voltage to avoid spurious tripping
- Housed in 92X92mm Din Standard housing.

2.0 Protection, Supervision Salient Features

- Three Phase Reverse Power Protection
- Three Phase Low forward Power Protection

Display and Measurement

- Display of R,Y,B Voltage (Phase to Neutral or Phase to Phase)
- Display of R,Y,B Phase Current
- Display of Pf, and KW

Salient Features

- Wide range SMPS auxiliary supply (supply range from 50 to 300 VAC/DC Or 8-35 VDC)
- Digital fast Fourier transformation.
- Selectable display of current in primary or secondary value
- Two digital inputs for external reset and external blocking.
- One common trip contact
- Three programmable alarm contact
- Selectable auto / manual scroll of measurement

3.0 Output Contact

Four NO contact Contacts are available, one is reserved for tripping function, three are programmable for alarm function.

- Trip (NO Contact)
- Alarm 1 (NO Contact)
- Alarm 2 (NO Contact)
- Alarm 3 (NO Contact)

4.0 Front Panel Switch

COP-P has four switch provided on its front panel. Switch can have more than one functions assigned to them. The table below describes the operation of these

S.No.	Switch Symbol	Switch Function	Description
1	↑	Next	Normal operation mode: In this mode this scrolls the displayed parameters. Programming Mode: It is used to select the next parameter to be programmed.
2	+	Increment	Programming Mode It's used to increment value of the selected parameters.
3	-	Decrement	Programming Mode It's used to decrement value of the selected parameters.
4	R	Reset	In manual reset option this Key is used to reset the fault LED indication.
5	R & -	Programming Mode Entry	Press "R" Key and than press "-" while the "R" Key is pressed to enter the programming mode.

5.0 Setting Procedure

COP has provision to program the operating parameters.

Press “R” & “-“ switch simultaneously.

The LCD shall display, “Parameter Mode”

To enter parameter setting mode press \uparrow .

To go to next menu press \oplus .

The LCD shall display “Set Alarm”.

This menu can be entered by pressing \uparrow .

To go to next menu press \oplus .

The LCD shall display “Set Blocking”.

This menu can be entered by pressing \uparrow .

6.0 Parameter Mode

Sl. No	Display	Explanation of parameter	Factory setting	Setting Range	Setting step
1	RPR IN P/Pn	Reverse power set value in % of nominal power*	0.10	0.05-0.5 P/Pn	0.01P/Pn
2	RPR > Def Time	Definite time delay in seconds for reverse power tripping.	10 Sec	0.01 – 150 Sec	0.01 Sec
3	LFP IN P/Pn	Low forward power set value in % of nominal power	0.10	0.05-0.5 P/Pn	0.01P/Pn
4	LFP > Def Time	Definite time delay in seconds, for low forward power tripping.	10 Sec	0.01 – 150 Sec	0.01 Sec
5	CT Ratio	Ratio of current transformer, Rated CT Primary current / Rated CT Secondary current	100	1-2500	1
6	Input Connection	Voltage connection to the controller is selectable for 3Phase 4 wire 230 V system and for 3Phase 3wire Ph to Ph 415 V connections.	Ph-Neu - 230 V	Ph-Neu-230 V, Ph-Ph-415 V	
7	PT Ratio	Ratio of current transformer, Rated CT Primary current / Rated CT Secondary current	1	1-1200	1
8	Reset Delay	Delay time for resetting the trip contact, after fault clearance.	1	0.1- 20 Sec	0.1 Sec.
9	Dis I in Pri/Sec	Selection of Current display in primary values or secondary values	Primary	Primary/Secondary	
10	Disp Auto Scroll	Measurement display auto scroll or manual scroll selection	Auto Scroll On	Auto Scroll On / Auto Scroll off	
11	Trip Reset	Reset type for tripped LED indication	Manual	Auto / Manual	

Nominal power of the relay is the power which is calculated at rated voltage and rated current of the relay

7.0 External Alarm Contact

Alarm Contact 1,2 & 3 can be programmed / activated on different protection functions e.g. for activating alarm 1 on reverse power, set 1. **By default no alarm is active.** If the alarms are required, they have to be programmed at the time of installing the relay.

The protections on which alarms can be programmed are:

Protection Function	Protection Symbol	Activated Alarm, default setting	Remark
Reverse Power	RPR	0	No Alarm activated on RPR
Low forward Power	LFP	0	No Alarm activated on LFP

8.0 Set Blocking Function

Group of Selected protection function can be disabled on activation of blocking input (By externally shorting terminal 7 and 8) e.g. If . Pr and LFP are programmed as enabled for blocking input then on shorting terminal 7 and 8 and High set over and under voltage protection will be blocked/disable.

Protection Function	Protection Symbol	Blocking enable/ Disable default setting	Remark
Reverse Power	RPR	Disable	Blocking function is disable
Low forward Power	LFP	Disable	Blocking function is disable

9.0 Reset – Auto / Manual

User can programme COP-P either as auto reset or manual reset relay.

- Auto Reset : The trip contact will reset automatically after Reset Delay, Indication will reset automatically after clearance of fault and expiry of reset delay.
- Manual Reset : The trip contact will reset automatically after Reset Delay, Indication will reset after pressing the reset button.

10.0 Terminal Description

Terminal Number	Description
1	R Phase Voltage
2	Y Phase Voltage
3	B Phase Voltage
4	Neutral
5	Not Connected
6	Not Connected
7	Common for external reset and blocking
8	External Block
9	External Reset
10	Auxiliary Supply
11	Auxiliary Supply
12	Not Connected
13	Trip NO Contact
14	Trip NO Contact
15	Alarm 1 NO
16	Alarm 2 NO
17	Alarm 3 NO
18	Common terminal for Alarm 1,2 & 3.
19,20	R Phase CT
21,22	Y Phase CT
23,24	B Phase CT

11.0 Model Selection Chart

Type	Protection	Rated Voltage	Rated Current	Auxilliary Voltage
COP	P : Reverse Power and low forward power relay	230 VAC	1 : Secondary 1A 5 : Secondary 5A	L: 8-35 VDC H: 50-300 VAC/DC

12.0	Technical specification	
AC voltage withstand		330 VAC, Continuously, (Phase to neutral)
Frequency Range		40-70 Hz
Rated Current		1A /5A
Current withstand		4 times rated current
Measurement Accuracy		
Voltage & Current		± 2%
Frequency		± 0. 05 Hz.
Surge 1.2/50Usec		2.5KV
Auxiliary Voltage		8-35V/DC OR 50-300 V AC/DC
Contact Rating		230 VAC, 5A
Cut out Dimensions		90mm X 90mm
Depth		120mm

13.0 Connection Diagram

COP-P- 3 Phase Reverse Power and low forward power protection relay

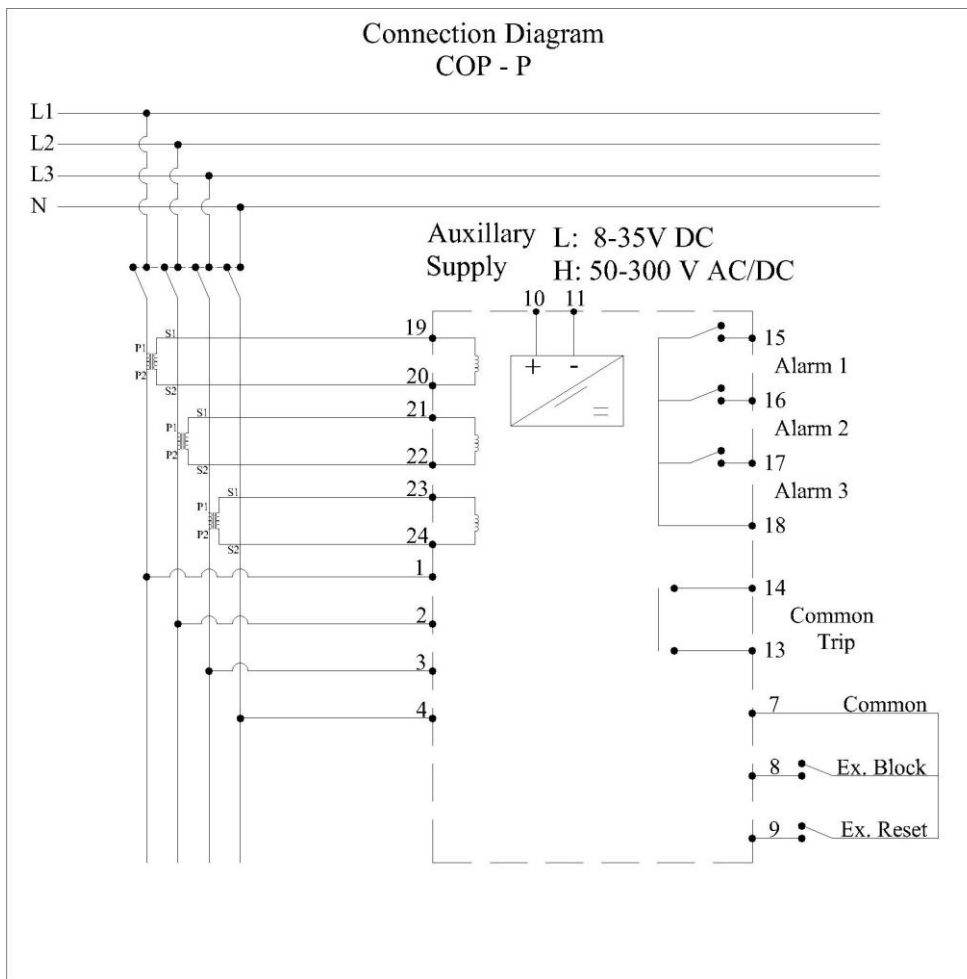

It is our endeavour to constantly upgrade our products, hence specifications are subject to change without any notice.