

## EARTH LEAKAGE PROTECTION RELAY



# INDEX

- 1. Introduction :**
- 2. Features :**
- 3. Functional Description :**
- 4. Technical Characteristics :**
- 5. LED Indication :**
- 6. Key Functions :**
- 7. Setting Mode :**
- 8. Reset Mode :**
- 9. Connection Diagram :**
- 10. Wiring Diagrams :**
- 11. Dimensional details :**

## 1.0 Introduction

Earth leakage relay are compact digital protection relay, equipped with customized 4 digit, single row display. Three navigator keys & numeric digits simplifies display & configuration of meter.

## 2.0 Features

- Simultaneous display of measured quantity & parameter
- Auto / Manual reset available
- Wide range of Earth Leakage current adjustment.
- Adjustable Earth Leakage trip time.
- Test feature to check complete product functionality.
- Reset feature through next switch on product.
- Remote reset feature.
- LED indications for all failure conditions.
- Wide Auxiliary supply range. (30V - 300VAC/DC)
- DIN rail mounting.

### • 3.0 Functional Description

#### Earth Leakage Protection

Earth Leakage relay is a micro controller based device meant to measure low level of leakage current and protect the faulty circuit from the system. Leakage current is sensed through core balance current transformer (CBCT). Earth leakage fault occurs when the current exceeds the set earth leakage current ( $I_e$ ) which is change in the setting mode by pressing **INC** or **DEC** key. Definite time trip occurs when the set time delay trip level expires which is adjustable from 0.02 sec to 10 sec which is change in the setting mode by pressing **INC** or **DEC** key. The Mains LED indicates the presence of Earth Leakage.

#### CBCT Connection

All conductors to be protected shall pass through the core balance current transformer. Main winding of current transformer and test winding should be connected to the product terminals by a twisted pair of 1 mm<sup>2</sup> wires. The CT wires should be placed adequately away from high current carrying conductors of source of strong magnetic field to avoid noise pickup. The Earth Leakage Relay also verifies CT connection. If CT is open power LED blinks CBCT error .

#### CBCT Dimensions

CBCT Variant	ID	L	B	T
CBCT38	38	90	70	20
CBCT55	55	117	97	20
CBCT92	92	155	132	20

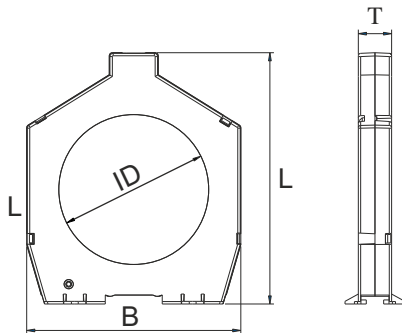

## 4.0 Technical Characteristics

<b>Auxiliary Supply</b>	<b>35VAC / DC-300 VAC / DC</b>
Power Consumption (max.)	5VA (APPROX.)
CT Rated Current	0.03-30Amp
Trip Time	0.02 - 10 Sec
Reset Type	AUTO / MANUAL
Reset Time	3 second
Power On Delay	< 500 ms
Test Function	YES
Setting Accuracy	+ / - 5%
Repeat Accuracy	+ / - 2%
Relay Output Contact	5A Res. @ 250 VAC / 30VDC
Temperature Range	-20°C to 55°C

## 5.0 LED Indication

LED	DISCRIPTION
MAINS	LED continuously ON if CBCT is healthy else start blinking,
TRIP	Trip LED indicates a earth fault occurrence.
>25%	LED lights up when earth current exceed 25% of rated current.
>50%	LED lights up when earth current exceed 50% of rated current.
>75%	LED lights up when earth current exceed 75% of rated current.

## 6.0 Key Functions

Key	Description
▲ INC	Increment the value of selected parameters & check the test function.
▼ DEC	Decrement the value of selected parameters.
▶ NXT	Scrolling to the next parameter in setting mode & reset the fault in manual mode

## 7.0 Setting Mode

To enter the setting mode, press DEC & NXT key together. For any change in value, press INC / DEC key. For next parameter, press NXT key.

Display	Description	Range	Factory Setting
E CU	Rated CT Secondary Current	0.03-30 A	0.10 A
E dL	Trip Delay	0.02-10 Sec	0.10 Sec
R dT	Reset Type	Auto / Manual	Manual

## 8.0 Reset Mode

### 1. Auto Reset

Relay reset occurs automatically when the Earth leakage fault disappears. Auto reset is enabled for 4 times only.

After 4 trips relay doesn't reset automatically. It has to be reset manually

### 2. Manual Reset

In Manual Reset, relay will be reset by pressing the next switch only after earth leakage fault disappears.

### 3. Remote Reset

For Remote reset, connect an external push button switch between Pin No. 5 & 6.

Test Function:

For test function, press and hold the INC button for duration of trip time selected. The relay will trip.

## 9.0 Connection Diagram

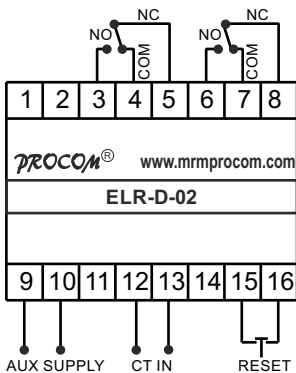

## 10.0 Wiring Diagrams

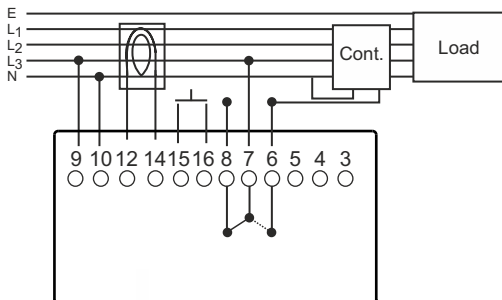

## 11.0 Dimensional details

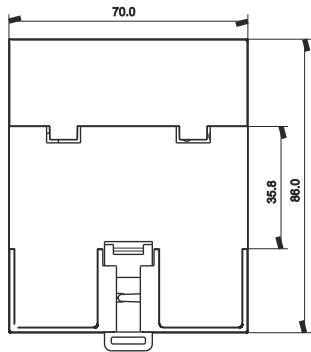
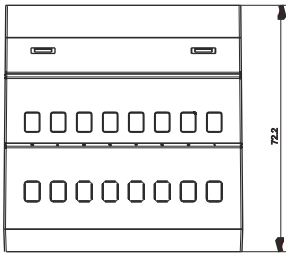
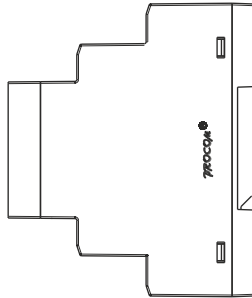
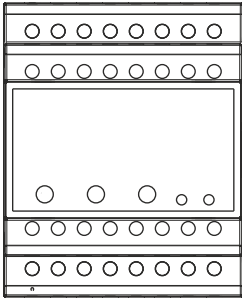

MRM **PROCOM**<sup>®</sup> Pvt. Ltd.

Plot No. 20-21, Industrial Estate

Sector-59 (II), HUDA, Faridabad-121004, Haryana

Phone: 0129-4700400 (10 Lines), E-mail : [info@mrmprocom.com](mailto:info@mrmprocom.com)

Website : [www.mrmprocom.com](http://www.mrmprocom.com)